

IS 3589 : 2001

भारतीय मानक

पानी और मलजल के लिए स्पात पाईप
(168.3 से 2 540 मिमी बाहरी व्यास के) — विशिष्टि

(तृतीय पुनरीक्षण)

Indian Standard

STEEL PIPES FOR WATER AND SEWAGE
(168.3 TO 2 540 mm OUTSIDE DIAMETER) —
SPECIFICATION

(*Third Revision*)

First Reprint JUNE 2004

ICS 77.140.30;41.140.60;91.140.80

© BIS 2001

BUREAU OF INDIAN STANDARDS
MANAK BHAVAN, 9 BAHADUR SHAH ZAFAR MARG
NEW DELHI 110002

April 2001

Price Group 7

FOREWORD

This Indian Standard (Third Revision) was adopted by the Bureau of Indian Standards, after the draft finalized by the Steel Tubes, Pipes and Fittings Sectional Committee had been approved by the Metallurgical Engineering Division Council.

This standard was originally published in 1966, first revised in 1981 and subsequently in 1991. While reviewing this standard in the light of the experience gained during these years, the committee felt to revise the same, taking note of the present practices being followed in the country and also overseas standards existing on the subject. In the revision of this standard the following main modifications have been made:

- a) Provision of outside diameters and thicknesses of pipes have been revised in accordance with the provisions of International Standards.
- b) Exhaustive tables for chemical composition of steels to be used and tensile properties of the pipes have been incorporated.
- c) Annexes A to D as the guideline for 'Protection Against Corrosion' have been added which recommend methods of protecting pipes against corrosion. It covers external as well as internal protection. Separate Indian Standards incorporating various types of protective coatings and materials thereof are expected to be published in due course of time.

In the formulation of this standard due weightage has been given to international coordination among the standards prevailing in different countries in addition to the practices in the country. This has been met by deriving assistance from the following publications:

- ISO 559-1991 Steel tubes for water and sewage (*second edition*), International Organization for Standardization.
- ISO 4200 : 1991 Plain end steel tubes, welded and seamless — General tables of dimensions and masses per unit length. International Organization for standardization.
- BS 534 : 1990 Steel pipes and specials for water and sewage. British Standards Institution.

For the purpose of deciding whether a particular requirement of this standard is complied with, the final value, observed or calculated, expressing the result of a test or analysis, shall be rounded off in accordance with IS 2 : 1960 'Rules for rounding off numerical values (*revised*)'. The number of significant places retained in the rounded off value should be the same as that of the specified value in this standard.

**AMENDMENT NO. 1 MAY 2002
TO
IS 3589 : 2001 STEEL PIPES FOR WATER AND
SEWAGE (168.3 TO 2 540 mm OUTSIDE DIAMETER) —
SPECIFICATION**

(*Third Revision*)

[*Page 1, clause 4.1(a), line 1*] — Substitute 'quantity' for 'quality'.

(*Page 3, Table 2*) — Substitute the following for the existing table:

Table 2 Chemical composition
(*Clauses 8.1 and 8.2*)

Steel Grade	Method of Manufacture	Chemical Composition (<i>Ladle Analysis</i>)				
		C	Mn	P	S	CE
		<i>Max</i>	<i>Max</i>	<i>Max</i>	<i>Max</i>	<i>Max</i>
Fe 330	Seamless (S)	0.16	1.20	0.040	0.040	—
Fe 330	Welded (ERW)	0.16	1.20	0.040	0.040	—
Fe 330	Welded (SAW)	0.16	1.20	0.040	0.040	—
Fe 410	Seamless (s)	0.20	1.30	0.040	0.040	0.45
Fe 410	Welded (ERW)	0.20	1.30	0.040	0.040	0.45
Fe 410	Welded (SAW)	0.20	1.30	0.040	0.040	0.45
Fe 450	Seamless (s)	0.25	1.20	0.040	0.040	0.45
Fe 450	Welded (ERW)	0.25	1.20	0.040	0.040	0.45
Fe 450	Welded (SAW)	0.25	1.30	0.040	0.040	0.45

(*Page 5, clause 11.1.1*) — Substitute the following for the existing formula:

$$M = (D - T) \times T \times 0.024\ 661\ 5$$

(*Page 6, Table 5, column 6, OD 1067 mm, thickness 11.0 mm*) — Substitute '286' for '186' mass in kg/m.

(*Page 8, Table 7*) — Substitute the following for the existing table:

Amend No. 1 to IS 3589 : 2001

**Table 7 Depth of sleeve, *X* and clearance *Y* for welded tubes
(Clause 17.2)**

Depth of Sleeve, <i>X</i> (1) mm	Outside Diameter of Pipe (2) mm	Tolerance (3) mm
50	168.3 upto 406.4	± 6
60	457.0 upto 1 219.0	± 6
75	1321.0 up to 2 540.0	± 6
Clearance <i>Y</i>, between the plain ends, mm <i>Max</i>		
4	168.3 up to 1 219.0	—
6	1321.0 up to 2 540.0	—

(MTD 19)

**AMENDMENT NO. 2 OCTOBER 2003
TO
IS 3589 : 2001 STEEL PIPES FOR WATER AND
SEWAGE (168.3 TO 2 540 mm OUTSIDE DIAMETER) —
SPECIFICATION**

(Third Revision)

*(Page 6, Table 5, col 3, Outside Diameter OD 168.3 mm, against Thickness
4.0 mm) — Substitute '16.2' for '18.2' .*

(MTD 19)

Printed at New India Printina Press, Khurja, India

**AMENDMENT NO. 3 MARCH 2006
TO
IS 3589 : 2001 STEEL PIPES FOR WATER
AND SEWAGE (168.3 TO 2540 mm OUTSIDE
DIAMETER) — SPECIFICATION**

(Third Revision)

(Title & General) — Delete the word 'gas' wherever it appears in the standard.

Substitute '168.3 mm outside diameter and above' for '168.3 to 2 032 mm outside diameter' wherever it appears.

(Page 2, clause 7.3) — Insert the following new clause after 7.3:

'7.3.1 Whenever agreed between the manufacturer and the purchaser, a maximum of two circumferential welds are permissible to make a full length. The tests for such tubes shall be mutually agreed. Minimum length of jointed tubes shall not be less than 1.5 meter.'

(Page 6, Table 5) — The mass of pipes of following sizes for the specified thickness and OD may be modified as given below:

Sl No.	Outside Diameter	Thickness	Mass
	mm	mm	kg/m
1	168.3	3.2	13.0
2	273	6.3	41.4
3	323.9	4.0	31.6
4	610	5.8	86.4
5	813	18	352.9
6	1 067	10	260.7
7	1 829	14.2	635.5

Amend No. 3 to IS 3589 : 2001

(*Page 9, Annex A, clause A-2*) — Insert the following sentence at the end of para:

'Alternatively 4 mm wire with a pitch of 50 mm may be wrapped over lined steel cylinder pipe with the tension of 50 to 65 MPa.'

(*Page 13, Annex B, clause B-1.1, line 4*) — Substitute the words 'coal tar' for 'coal rat'.

(MTD 19)

AMENDMENT NO. 4 JUNE 2010
TO
IS 3589 : 2001 STEEL PIPES FOR WATER AND SEWAGE
(168.3 TO 2 540 mm OUTSIDE DIAMETER) —
SPECIFICATION

(Third Revision)

(Page 3, Table 2, read with Amendment No. 1) — Add the following Note below the table.

‘NOTE — For each reduction by 0.01 percent Carbon below the specified maximum, an increase of 0.05 percent above the maximum of manganese is permissible up to a maximum of 1.50 for grades Fe410 and 450.’

(MTD 19)

Reprography Unit, BIS, New Delhi, India

Indian Standard

STEEL PIPES FOR WATER AND SEWAGE
(168.3 TO 2 540 mm OUTSIDE DIAMETER) —
SPECIFICATION
(Third Revision)

1 SCOPE

This standard applies to seamless and welded carbon steel pipes for water and sewage of outside diameter from 168.3 to 2 540 mm.

2 REFERENCES

The following Indian Standards contain provisions which through reference in this text constitute provisions of this standard. At the time of publication, the editions indicated were valid. All standards are subject to revision and parties to agreements based on this standard are encouraged to investigate the possibility of applying the most recent editions of the standards indicated below:

<i>IS No.</i>	<i>Title</i>
228	Methods of chemical analysis of steels (issued in various parts)
1608 : 1995	Methods for tensile testing of steel products (<i>second revision</i>)
2328 : 1983	Method for flattening test on metallic tubes (<i>first revision</i>)
3803 (Part 1) : 1989/ISO 2566 : 1984	Method for elongation conversions for steel : Part 1 Carbon and low alloy steels (<i>second revision</i>)
4711 : 1974	Methods for sampling of steel pipes, tubes and fittings (<i>first revision</i>)
4736 : 1986	Hot-dip zinc coatings on mild steel tubes (<i>first revision</i>)

3 TERMINOLOGY

For the purpose of this standard, the following definitions shall apply.

3.1 Pipe (Tube)

A long hollow open ended object of circular cross-section. The term tube is synonymous with the term pipe.

3.2 Hydrostatic Test Pressure

Test pressure for hydraulic testing at the works.

3.3 Random Lengths

The term random length denotes the normal manufacturing length falling within a range agreed to between the purchaser and the manufacturer.

3.4 Exact Lengths

Pipes cut to a specified length on which only a small tolerance is allowed.

3.5 Effective Length

The actual length that a pipe contributes when correctly assembled in a run of piping. This dimension excludes the additional length contributed by a slip-on type coupling when that is used.

4 INFORMATION TO BE SUPPLIED BY THE PURCHASER WHILE PLACING ORDER**4.1 Mandatory Informations**

- a) the quality ordered (total tonnage, total length or number of tubes);
- b) the number of this standard;
- c) the grade of steel;
- d) the outside diameter and thickness;
- e) the length of pipes;
- f) the end preparation (bevelled ends or special joints); and
- g) the type of external coating and/or interior lining as agreed previously with the manufacturer.

4.2 Optional Requirements

Certain optional and supplementary requirements may also be specified as under:

- a) the steel making processes and deoxidation procedures;
- b) the tube making process;
- c) delivery condition;
- d) ladle analysis;
- e) delivery lengths; and
- f) end preparation.

5 DESIGNATION

5.1 The pipes shall be designated by the method of manufacture followed by the grade number corresponding to the minimum specified tensile strength in MPa following the symbol Fe as given in Table 1.

Example :

ERW — Fe410 indicates electric resistance welded or induction welded steel pipe having a minimum tensile strength of 410 MPa.

Table 1 Designation of the Grades of the Pipes

Method of Manufacture of Pipe	Reference	Steel Grades Applicable		
		(3)	(4)	(5)
(1)	(2)	(3)	(4)	(5)
Seamless	S	Fe330	Fe410	Fe450
Electric resistance including induction welded	ERW	Fe330	Fe410	Fe450
Submerged arc welded (including spirally welded)	SAW	Fe330	Fe410	Fe450

NOTE — Method of manufacture of pipe and steel grades other than specified above shall be as agreed to between the manufacturer and the purchaser.

5.2 The size of the pipes shall be designated by their outside diameters in mm.

6 QUALITY OF STEEL

Pipes shall be manufactured with the steel produced by the open hearth or electric furnace or one of the basic oxygen processes. Other processes may be used by agreement between the purchaser and the manufacturer.

7 MANUFACTURE OF THE PRODUCT

The pipes shall be manufactured by one of the following processes.

7.1 Seamless Pipes

The pipes shall be manufactured by using a seamless process and shall either be hot or cold finished.

7.2 Electric Resistance Welded Pipes

The pipes shall be manufactured from plate, sheet or strip welded continuously by the passage of an electric current across the abutting edges longitudinally or spirally. The finished pipes shall not include welds used for joining lengths of the hot or cold, flat rolled strips prior to tube forming. The external weld bead shall be removed completely.

7.3 Submerged Arc Welded Pipes

The pipes shall be manufactured from plate, sheet or

strip with either a single or double longitudinal seam or a spiral seam and welded across the abutting edges by an automatic submerged arc welding process using at least two runs, one of which shall be on the inside of the pipes.

7.4 Repair by Welding

7.4.1 Injurious defects in pipe wall, provided their depth does not exceed one third of the specified wall thickness, shall be repaired by welding.

7.4.1.1 Defects in the welds, such as sweats and leaks, unless otherwise specified may be repaired or piece rejected at the option of the manufacturer for submerged arc welded pipes.

7.4.1.2 Welds of the electric resistance welded pipes may be repaired only by agreement between the purchaser and the manufacturer.

7.4.1.3 Repairs of this nature shall be made by completely removing the defect, cleaning the cavity and then welding.

7.4.2 All repaired pipes shall be retested hydraulically in accordance with 10.

8 CHEMICAL COMPOSITION

8.1 Ladle Analysis

The ladle analysis of steel shall be as given in Table 2. The analysis of steel shall be carried out either by the method specified in IS 228 and its relevant parts or any other established instrumental/chemical method. In case of dispute the procedure given in IS 228 and its relevant parts, shall be the referee method. However, where the method is not given in IS 228 and its relevant parts, the referee method shall be as agreed to between the purchaser and the manufacturer.

8.2 Product Analysis

Permissible variations in the case of product analysis from the limits specified in Table 2 shall be as given in Table 3.

9 MECHANICAL PROPERTIES

9.1 Tensile Strength

The tensile properties of strip cut longitudinally (excluding the weld) from selected pipes shall show the properties as given in Table 4 in respect to specific type of pipes as manufactured. The percentage elongation shall be determined on a gauge length of $5.65\sqrt{S_0}$. If other gauge lengths are used conversion shall be made as in IS 3803 (Part 1).

9.2 Flattening or Bend Test

9.2.1 Flattening Test for ERW Pipes

At the option of the manufacturer flattening or bend

Table 2 Chemical Composition
(Clauses 8.1 and 8.2)

Steel Grade	Method of Manufacture	Chemical Composition (Ladle Analysis)				
		C Max	Mn Max	P Max	S Max	CE Max
Fe330	Seamless (S)	0.16	1.20	0.040	0.040	—
Fe330	Welded (ERW)	0.16	1.20	0.040	0.040	—
Fe410	Seamless (S)	0.20	1.30	0.040	0.040	0.45
Fe410	Welded (ERW)	0.20	1.30	0.040	0.040	0.45
Fe450	Seamless (S)	0.25	1.20	0.040	0.040	0.45
Fe450	Welded (ERW)	0.25	1.20	0.040	0.040	0.45
Fe450	Welded (SAW)	0.25	1.30	0.040	0.040	0.45

NOTES

- 1 Elements not quoted on this table are not to be intentionally added other than for the purpose of finishing the heat.
- 2 For semi-killed quality silicon content shall be 0.08 percent maximum.
- 3 When the steel is aluminium-killed, the total aluminium content shall not be less than 0.02 percent. When the steel is silicon-killed, silicon content shall not be less than 0.10 percent. When the steel is silicon-aluminium-killed, the silicon content shall not be less than 0.03 percent and total aluminium content shall not be less than 0.01 percent.
- 4 Micro alloying may be allowed subject to mutual agreement between the purchaser and the supplier. Micro alloying elements like Nb, V or Ti, when used individually or in combination, the total content shall not exceed 0.20 percent.
- 5 Nitrogen content of steel shall not exceed 0.012 percent which shall be ensured by the manufacturer by occasional check analysis.
- 6 For permissible deviations on product analysis, see Table 3.

Table 3 Permissible Variation for Product Analysis
(Clause 8.2)

Constituent (1)	Variation Over Specified Limit, Percent, Max (2)
Carbon	0.02
Manganese	0.04
Sulphur	0.005
Phosphorus	0.005

test shall be carried out depending upon the thickness and outer diameter of the pipes.

The test shall be made on a ring sample not less than 40 mm in length cut from the ends of selected tubes which shall be flattened between parallel plates keeping the weld at 90° to the direction of the force. No opening shall occur by fracture in the weld until the distance between the plates is less than 75 percent of the original outside diameter of the pipe and no cracks or breaks on the metal elsewhere than in the weld shall occur until the distance between the plates is less than 60 percent of the original outside diameter.

9.2.2 Bend Test for ERW Pipes

No bend test is applicable to ERW pipes.

Table 4 Mechanical Properties at Room Temperature
(Clause 9.1)

Steel Grade	Method	R_m Tensile Strength MPa Min	R_e Yield Stress MPa Min	A Elongation Percent $GL5.65\sqrt{S_0}$ Min
Fe330	ERW, Seamless and SAW	330	195 ¹⁾	20
Fe410	ERW, Seamless and SAW	410	235 ¹⁾	18
Fe450	ERW, Seamless and SAW	450	275 ¹⁾	15

¹⁾Yield stress values are for design purposes only either the upper yield stress ReH , or the 0.5 percent of proof stress (total elongation) $ReH 0.5$ is to be determined.

9.2.3 Flattening Test for Seamless Pipes

This test shall be carried out in accordance with IS 2328. A ring, not less than 40 mm long, cut from one end of each selected pipe shall when cold be flattened between two parallel flat surfaces without showing either crack or flaw, until the distance between plates H (in mm) measured under load, is not greater

than the value given by the following equation:

$$H = \frac{(1 + C) a}{C + a/D}$$

where

- a = specified thickness of the pipe (mm),
- D = specified outside diameter of the pipe (mm),
- C = a constant dependent on the steel grade value of C ,
= 0.09 for Fe330
= 0.07 for Fe410 and Fe450.

NOTES

- 1 If any flaw appears during flattening test, it may be removed by grinding or filing. In such cases if the remaining wall thickness is not less than the minimum permitted thickness as per clause the sample shall be accepted.
- 2 Superficial rupture resulting from surface imperfections shall not be a cause of rejection.

9.3 Guided Bend Test (For SAW Pipes)

Strips not less than 40 mm wide, cut circumferentially from pipes perpendicular to weld seam with the weld near the middle of the sample shall, without fracture, be doubled over a round bar the diameter of which shall be calculated as given below. The weld reinforcement shall be removed from the faces.

9.3.1 One face bend and one root bend specimen, both conforming to Fig.1 shall be bent approximately 180° in a jig substantially in accordance with Fig.2 for any combination of diameter, wall thickness and grade. The maximum value for jig dimension A may be calculated by the formula given below. The manufacturer shall use a jig based on this dimension or a smaller dimension at his option.

$$A = \frac{1.15 (D - 2t)}{\frac{eD}{t} - 2e - 1}$$

where

- 1.15 = peaking factor,
- D = specified OD in mm,
- t = specified wall thickness in mm, and
- e = strain in mm
= 0.132 5 for Grade Fe330,
= 0.127 5 for Grade Fe410 and Grade Fe450.

9.3.2 The specimens shall not fracture completely. Cracks 6.35 mm or less in length at the edge of the specimen or 3.18 mm or less in length in the centre of

the specimen shall be disregarded. Any crack greater than 3.18 mm in length and regardless of depth located within the weld metal shall be a cause for rejection. Any pop-out greater than 3.18 mm in length (6.35 mm at the edge) and 12.5 percent or less of the specified wall thickness in depth and located in the parent metal, the heat affected zone, or the fusion line, shall not be the cause for rejection.

Any test specimen that shows defective preparation, or material imperfection unrelated to the intent of the particular mechanical test whether observed before or after testing, may be discarded and replaced by another specimen from the same length of the pipe.

9.3.3 On examination of the bent specimen, opening out of a slight defect due to incomplete root penetration or lack of root fusion need not be considered a cause for rejection provided the defect has sound metal at the back and on either side of it. In border line cases, further tests shall be made on specimens from the same weld adjacent to the original test specimen.

10 HYDRAULIC PRESSURE TEST

Each pipe shall be hydraulically tested at the manufacturer's works before the pipe is coated, wrapped and lined.

10.1 The hydraulic test pressure shall be the pressure calculated as per the following formula:

$$P = \frac{2ST}{D}$$

where

- P = hydraulic test pressure MPa,
- D = specified outside dia of the pipe in mm,
- T = specified thickness of the tube in mm, and
- S = stress 60% of the specified minimum yield stress in MPa. The maximum test pressure to be limited to 5 MPa wherever applicable.

10.1.1 The hydraulic test pressure shall be applied for 5 s.

10.2 The hydraulic test may be substituted by a Non-Destructive Test at the option of the manufacturer.

10.2.1 Method of NDT and the acceptance level shall be as agreed to between the manufacturer and the purchaser.

11 DIMENSIONS AND MASS PER METRE RUN OF PIPES

11.1 Preferred outside diameter and thickness of the pipes are specified in the Table 5. The table also provides the nominal mass per metre run of the pipes against each dimension.

NOTE — Table 5 gives a selection of preferred outside diameters and thicknesses, other sizes not included in the table may be supplied as specified by the purchaser.

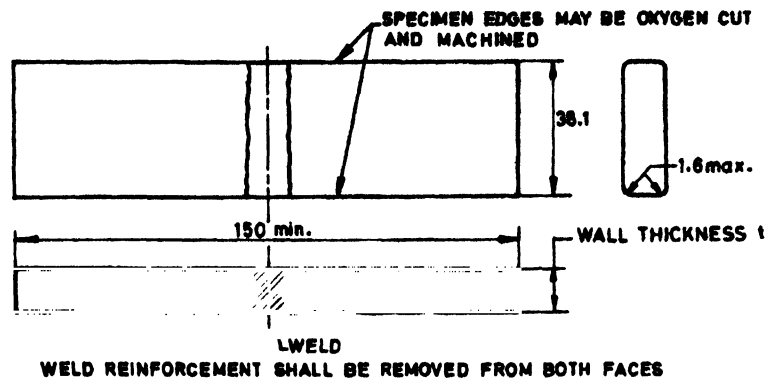

All dimensions in millimetres.

FIG. 1 GUIDED BEND TEST SPECIMEN

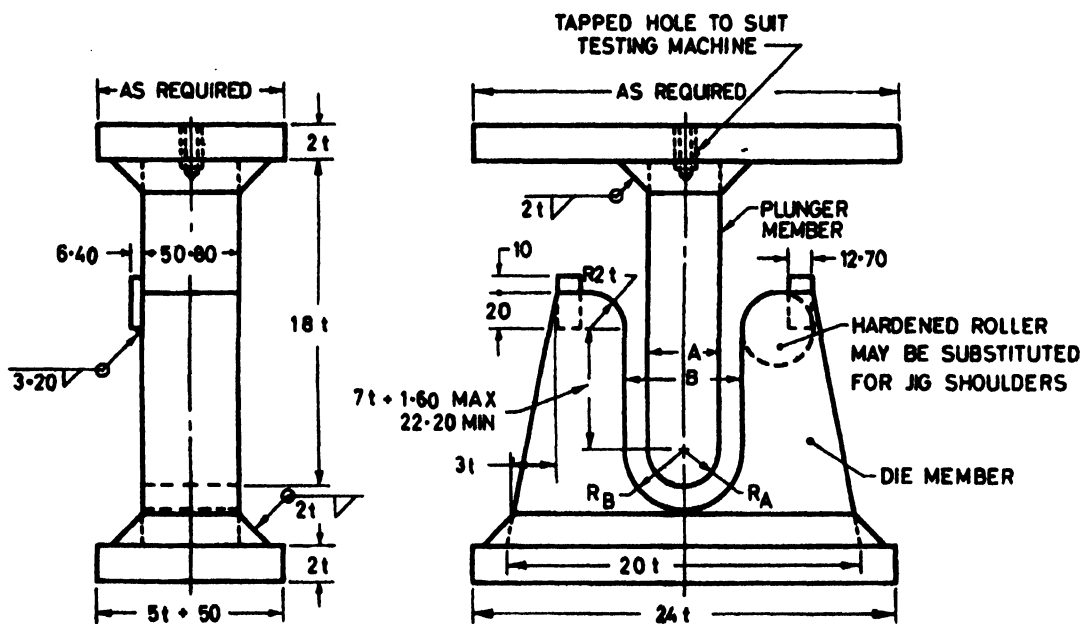

$$R_A = \frac{A}{2}, B = A + 2t + 3.2 \text{ mm and } R_B = \frac{B}{2}$$

All dimensions in millimetres.

FIG. 2 JIG FOR GUIDED BEND TEST

11.1.1 Mass per metre run of the pipes can also be worked out by the formula as under:

$$M = (D - T) \times T \times 0.246 615$$

where

- M = mass of the pipe kg/metre,
- D = nominal outside diameter of the tube in mm,
- and
- T = Nominal thickness of the tube in mm.

12 TOLERANCES

12.1 Tolerance on Mass

The tolerance on mass per cart load of 10 tonnes or above shall be ± 7.5 percent on the nominal theoretical mass of the tubes.

12.2 General

The tolerance on the dimensions of the pipes shall be as specified in 12.3 and 12.4.

Table 5 Preferred Dimensions and Mass per Metre Length of Pipes
(Clause 11.1)

Outside Diameter OD mm	Thickness mm	Mass kg/m	Outside Diameter OD mm	Thickness mm	Mass kg/m	Outside Diameter OD mm	Thickness mm	Mass kg/m
168.3	2.6	10.6	508	5.0	62	1 219	10.0	298
	3.2	12		5.6	69.4		11.0	328
	4.0	18.2		6.3	77.9		12.5	372
219.1	4.5	18.2	610	11.0	135	1 422	12.5	435
	2.6	13.9		5.8	83.5		14.2	493
	3.6	19.1		6.3	93.8		1 626	14.2
273	4.5	23.8	711	12.5	184	1 829	16.0	635
	6.3	33.1		6.3	109		14.2	634
	3.6	23.9		7.1	123		16.0	715
323.9	4.0	26.5	813	14.2	244	2 032	17.5	782
	5.0	33		7.1	141		16.0	795
	6.3	41.1		8.0	159		17.5	869
355.6	4.0	31.8	914	18.0	314	2 235	20.0	992
	4.5	35.4		8.0	179		17.5	957
	5.6	44		8.8	196		20.0	1 093
406.4	7.1	55.5	1 016	10.0	223	2 540	22.2	1 211
	4.0	34.7		17.5	387		20.0	1 243
	5.0	43.2		8.8	219		22.2	1 379
457	5.6	48.3	1 067	10.0	248	2 540	25.0	1 551
	8.0	68.6		20.0	491			
	4.0	39.7		8.8	230			
457	5.0	49.5	1 118	10.0	251			
	6.3	62.2		11.0	186			
	8.8	86.3		8.8	241			
457	4.0	44.7	1 118	10.0	273			
	5.0	55.7		11.0	300			
	6.3	70						
	10.0	110						

12.3 Outside Diameter, Thickness and Height of Internal Weld Bead or Reinforcement

12.3.1 The tolerance on outside diameter shall include ovality except for submerged arc welded pipes.

The tolerance on the specified outside diameter of pipe wall shall be as given in Table 6.

Table 6 Tolerances on Outside Diameter of Pipes

Outside Dia (For All Sizes)	Tolerance
(1)	(2)
For seamless pipes	± 1%
For ERW & SAW pipes	± 0.75%

12.3.2 Thickness

The thickness tolerance shall not apply to the weld area. The maximum height of the weld bead on the internal surface of the pipe shall not exceed 60 percent of nominal wall thickness. The tolerance on the specified wall thickness shall be as follows:

ERW pipe	—	± 10%
SAW and seamless pipe	—	$\left(\begin{array}{l} +20 \\ -12.5 \end{array} \right) \%$

12.3.3 Ovality

12.3.3.1 Ovality shall not exceed 1 percent of the specified outside diameter for pipes having diameter to thickness ratio not exceeding 100. Where the diameter

to thickness ratio exceeds 100 the tolerance on ovality is not specified and should be agreed between the manufacturer and the purchaser.

12.4 Random Length

12.4.1 Steel tubes shall be supplied in single random lengths from 4 to 7 m or double random length of 7 to 14 m. For orders over 200 m of any one size of pipes, it shall be permissible to supply short random lengths from 2 to 4 m for single random lengths and 4 to 7 m for double random lengths provided the total of such lengths does not exceed 7.5 percent of the total length.

12.4.2 Where length is specified as 'exact' or 'cut lengths' the permissible variations shall be ± 10 mm for length up to and including 6 m.

12.4.3 Supply in any length and the tolerances other than the above specified shall be mutually agreed to between the manufacturer and the purchaser.

12.5 Straightness

12.5.1 Finished pipe shall not deviate from straightness by more than 0.2 percent of the total length.

12.5.2 Checking shall be carried out using a taut string or wire from end to end, along the side of the pipe to measure, the greatest deviation.

13 NUMBER, SELECTION AND PREPARATION OF SAMPLES AND TEST PIECES

13.1 Unless otherwise agreed to between the manufacturer and the purchaser the procedure for sampling of pipe for various tests and criteria for conformity shall be as given in IS 4711.

13.1.1 The test samples shall be cut from pipes in the final condition of supply.

13.1.2 One set of mechanical tests as specified in 9 shall be carried out from samples taken of each tube.

13.1.3 For the tensile test, the dimensions of the test piece shall comply with the appropriate requirements of IS 1608. For welded pipes the tensile test piece shall not include the weld unless the pipe is tested in full section.

NOTE — For the tensile test, the piece may be taken either longitudinally or transversely from the pipe at the option of the manufacturer.

13.1.4 For a bend test on the weld, two pieces shall be prepared, one for a face bend test and one for a root bend test. Both test pieces shall be not less than 40 mm wide and cut perpendicular to the weld line from one end of each selected pipe so that the weld is in the middle of the test piece and 90° to the longer sides. The weld reinforcement shall be removed from

both faces. The length of the test pieces shall be selected by the manufacturer to suit the equipment used for the test.

NOTE — The test pieces may be flattened before testing.

14 VISUAL INSPECTION, APPEARANCE AND WORKMANSHIP

14.1 The pipes shall be clean and free from such defects as can be established by visual inspection in accordance with this standard.

14.2 It shall be permitted to dress by grinding or machining surface marks and imperfections such as scabs, seams, tears, laps, slivers or gouges provided that the thickness of the tube after dressing does not fall below the nominal thickness by more than the tolerance specified in this standard.

14.3 All dressed areas shall blend smoothly into the contour of the pipe.

14.4 For pipes which have a thickness to diameter ratio equal to or less than 0.03, isolated dents shall not be cause for rejection provided that they do not exceed a depth greater than 6 mm maximum for pipes below 610 mm OD and not exceed 1 percent of OD for pipes over 610 mm OD measured as a gap between the point of the dent and a prolongation of the original contour of the pipe. The length of the dent in any direction shall not exceed one half the pipe diameter.

14.5 The ends shall be cut nominally square with the axis of the pipe and shall be free from excessive burrs.

15 CONDITION OF SUPPLY

Subject to the agreement between the manufacturer and the purchaser the pipes may be supplied bare or with anti rust coatings.

16 GUIDELINES OF COATING

16.1 Any type of protective coating, if required, may be agreed to between the manufacturer and the purchaser. Guidelines for the types of coating are given in Annexes A to D.

16.2 Where tubes are required to be galvanized the zinc coating on tubes shall be in accordance with IS 4736.

17 JOINTS AND ENDS

17.1 The type of joints and ends of pipes shall be specified by the purchaser. The types of joints and ends recognized under this standard are:

- a) Plain ends or bevelled ends for butt welding (*see* Fig.3A and 3B) unless otherwise agreed, bevelled ends shall be bevelled to an angle of

30° ± 0.5 degree measured from a line drawn perpendicular to the axis of the pipe. The root face shall be 1.6 ± 0.8 mm.

- b) Joints with sleeves joint or swelled and plain ends for welding (see Fig. 4).

NOTE — The root face of the bevel may be prepared by hand fitting, if required.

17.1.1 Pipe with sleeve welded joints shall be supplied with the plain and parallel end and sleeve and tapered to approximately 3 mm per 100 mm. The ends shall be sized and gauged so as to ensure that the plain end will freely enter the sleeve and thereafter be capable of being forced home.

17.2 All sleeves shall be made so that the plain end shall enter the specified minimum depth given in Table 7. The manufacturer shall make available to inspection at the works metal gauges of suitable dimensions to enable the purchaser or his representative to ascertain that the sleeve and plain end comply with the requirements of the specification.

Table 7 Depth of Sleeve, X and Clearance Y for Welded Pipes

(Clause 17.2)

Dimensions	Outside Diameter of Pipe	Tolerance
mm	mm	mm
(1)	(2)	(3)
50	168.3 up to 406.4	(+/-)6
60	457 up to 1 219	(+/-)6
75	1 321 up to 2 540	(+/-)6
Clearance Y between the plain ends,mm	168.3 up to 1 219	(+/-)4
Max	1 321 up to 2 540	(+/-)6

18 MARKING

18.1 Each pipe shall be legibly marked with the following details:

- a) Manufacturer's name or trade-mark;

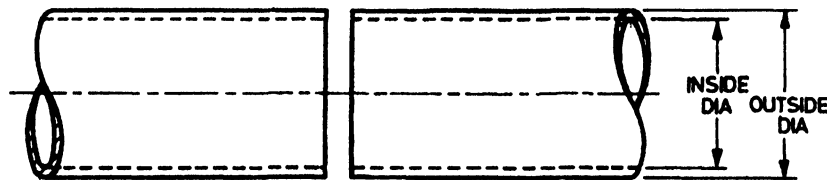

3A Plain Ends for Butt Welding

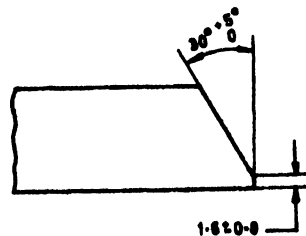
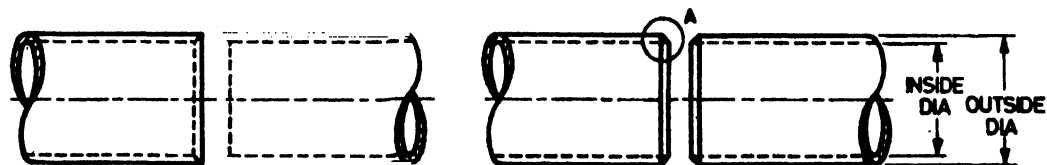

Enlarged View of 'A'

3B Bevelled Ends for Butt Welded Joints

FIG. 3 TYPES OF ENDS

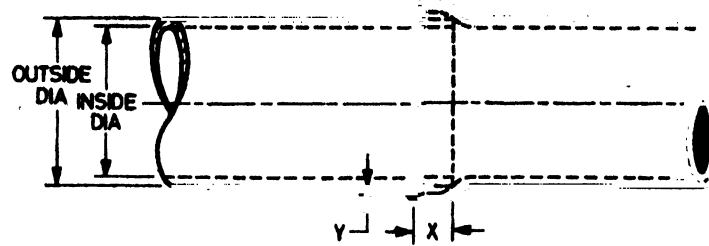

FIG. 4 SLEEVE JOINT OR SWELLED AND PLAIN END FOR WELDING

- b) Outside diameter and specified wall thickness; and
- c) Pipe designation.

Example:

For a pipe manufactured under trade name ABC having 508 mm outside diameter 8 mm specified wall thickness conforming to SAW 410 grade shall be legibly marked as follows:

ABC - 508.0 - 8 - SAW 410

18.2 BIS Standard Mark

The pipes may also be marked with the Standard Mark.

18.2.1 The use of the Standard Mark is governed by the provisions of the *Bureau of Indian Standards Act, 1986* and the Rules and Regulations made thereunder. The details of conditions under which a licence for the use of the Standard Mark may be granted to manufacturers or producers may be obtained from the Bureau of Indian Standards.

ANNEX A

(Foreword and Clause 16.1)

GUIDELINES FOR PROTECTION AGAINST CORROSION**A-1 CEMENT-MORTAR PROTECTIVE LINING AND COATING FOR STEEL PIPE SHOP APPLIED**

The inside of all pipe shall receive a cement-mortar lining applied by centrifugal spinning or by a method known to provide equivalent results.

The outside of pipe shall receive a reinforced cement-mortar coating applied by mechanical placement, pneumatic placement, or a method known to provide equivalent results.

A-2 REINFORCEMENT

Spiral-wire reinforcement for pipe coating. Steel wire shall be a minimum size of 3 mm. The wire shall conform to the requirements of IS 432 (Part 1). Reinforcing wire need not be galvanized unless otherwise specified by the purchaser.

Reinforcement shall be 50 × 100 mm welded wire fabric. The wire shall conform to the requirements of IS 1566. Unless otherwise specified by the purchaser, wire fabric reinforcement may be either crimped or uncrimped.

A-3 PORTLAND CEMENT

Portland cement shall conform to the requirements of IS 269/IS 8041/IS 1489/IS 8112 for cement, or as otherwise specified by the purchaser. The minimum cement content shall be 330 kg/m³.

A-3.1 Sand

Sand shall consist of inert materials having hard, strong, durable uncoated grains conforming to the requirements to IS 2116.

A-4 MIXING WATER

Water shall be clean, colourless, and free from injurious quantities of organic matter, alkali, salt, or other impurities that might reduce the strength, durability, or other desirable qualities of the mortar, the maximum water cement ratio shall not exceed 0.5:1.

A-5 SEAL COAT PAINT

The paint or otherwise materials used to prevent the rusting of steel surfaces and providing seal coat of mortar lining or coating before pipe installation shall be a quick drying, corrosion-resistant material with

IS 3589 : 2001

good bonding properties to steel and shall dry tackfree and smooth within 4 h after application. The paint material applied to the interior of pipe or fittings shall be free from contaminants that may be harmful to the end user of the potable water.

A-6 LINING

A-6.1 Cement Mortar

Cement mortar shall be composed of cement, sand and water, well mixed and of proper consistency to obtain a dense, homogeneous lining that will adhere firmly to the pipe surface. Proportion 2 parts of sand to 1 part cement, by weight. The soluble chloride-ion (Cl) content of the cement mortar mix shall not exceed 0.15 percent, expressed as a percentage of cement weight.

A-6.2 Thickness of Lining

Cement mortar lining shall be uniform in thickness, except of joints or other discontinuities in the pipe wall. Lining thickness shall be as listed in Table 8 or as specified by the purchaser. Ends of lining shall be left square and uniform with regard to the longitudinal axis of the pipe, and the lining holdback shall be as specified by the purchaser for the type of joints required.

Table 8 Thickness of Cement Mortar Lining

Outside Dia of Steel Pipe mm (1)	Minimum Thickness of Lining mm (2)	Tolerance mm (3)
168.3 to 323.9	6	+ 2 - 0
355.6 to 610	7	+ 2 - 0
660 to 1 219	9	+ 2 - 0
1 321 to 2 540	12	+ 3 - 0

A-6.3 Equipment

A-6.3.1 Lining

Straight sections of pipe shall be lined by use of a spinning machine specifically designed and built for the purpose of rotating the pipe section and centrifugally applying cement mortar lining to the interior of steel pipe or by a method known to provide equivalent result.

A-6.3.2 Mixing

The mortar shall be mixed in batches. The amount of cement and sand entering into each batch shall be measured by weight. The quantity of water entering the mixer shall be measured automatically by an adjustable device, or it shall be otherwise measured to ensure that the correct quantity of water is being added.

A-6.4 Machine Lining

A-6.4.1 Bracing

When required to prevent distortion or vibration during the spinning, each section of pipe shall be suitably braced with external or internal supports appropriate to the equipment.

A-6.4.2 Finish

After the mortar has been distributed to a uniform thickness, the rotation speed shall be increased to produce a dense mortar with a smooth surface.

A-6.4.3 Surplus Water

Provision shall be made for removal of surplus water by air blowing, tilting of the pipe or other methods approved by the purchaser.

A-6.5 Defective Lining

A-6.5.1 General

All defects, including but not restricted to sand pockets, voids, oversanded areas, blisters, and cracking as a result of impacts, shall be cut out and replaced by hand or pneumatic placement to the same thickness as required for the mortar lining.

A-6.5.2 Lining Cracks

Temperature and shrinkage cracks in the mortar lining less than 1.5 mm in width need not be repaired.

A-6.6 Curing of Lining

Immediately after completion of spinning, the pipe sections, may be moved to a curing area. Care shall be exercised at all time to prevent damage to the lining. At the option of the manufacturer, linings shall be either accelerated cured or moist cured.

A-6.6.1 Moist Curing

On arrival at the curing area, but not later than 30 min after completion of the lining operation, pipe ends shall be covered with plastic or wet burlap for a minimum period of 24 h before applying the exterior coating, if such coating is specified. If a cement mortar exterior coating is not specified, the lining shall be kept moist for four days before shipment. In either case, the lining shall be cured for a total period of four days before shipment. The ends of the pipe sections shall be kept closed during the curing period, with plastic end caps, except when sprinkling hands are used, the reinforcement and outside coatings are being applied or accelerated curing is being substituted. If the plastic end caps are installed at that time, they can be used for shipping to the jobsite. The manufacturer shall exercise care and diligence to avoid drying to or cracking of the lining.

A-6.6.2 Accelerated Curing

Accelerated curing may begin immediately on arrival of the pipe at the curing area, but the temperature of the pipe shall not exceed for 3 h or until the mortar has taken its initial set, whichever occurs first.

The ambient vapour shall then be maintained at a temperature between 45°C and 65°C at a relative humidity of not less than 85 percent for a minimum curing period of 6 h, after which the exterior coating may be applied, if such coating is specified. If cement mortar coating is not specified, the lining shall be cured for 18 h before shipment. In either case, the lining shall be cured for a total period of 18 h before shipment.

A-7 MORTAR LINING TEST CYLINDERS**A-7.1 Mortar Test Cylinders**

A set of at least two standard test cylinders, 50 mm in diameter by 300 mm in length, shall be made each day. The test cylinders shall be cured with the pipe at the same temperature and for the same total length of time. Other sizes cylinders, such as 50 mm × 100 mm may be used to test compressive strength. If the 7-day test requirements, then the 28-day test need not be completed.

A-7.2 Centrifugal Test Cylinders

Centrifugally spun test cylinders may be substituted for mortar test cylinders, at the option of the manufacturer. Test cylinders shall be spun about their longitudinal axes in 150 mm diameter by 300 mm long steel molds at a speed that will simulate the compaction of mortar in the lining to produce a spun cylinder wall thickness of at least 35 mm. The net cross-sectional area of the hollow cylinder shall be used to determine its compressive strength. Damaged cylinders shall not be tested.

A-7.3 Strength of Mortar Lining

Mortar test cylinders shall obtain a minimum compressive strength of 18 MPa in 7 days and 31 MPa in 28 days. Pipe made with mortar lining that does not meet the strength requirements set forth herein shall be subject to rejection.

The average of any 10 consecutive strength tests of cylinders representing each mortar mix shall be equal to or greater than the specified strength, and not more than 20 percent of the strength tests shall have values less than the specified strength. No cylinder test result shall be less than 80 percent of the specified strength.

A-8 COATING**A-8.1 General**

When specified, the external protection of steel pipe

shall be a reinforced cement mortar coating applied over the outer surfaces of the pipe sections. If the pipe has been mortar lined, the curing times specified above must elapse before the coating is applied.

A-8.2 Cement Mortar

Cement mortar applied by mechanical placement or by the steampneumatic process shall consist of not more than 3 parts sand to 1 part cement, by weight. The water in the mixture shall be carefully controlled so that the mortar will not run, sag, or segregate.

The soluble chloride-ion (Cl) content of the cement mortar mix shall not exceed 0.15 percent, expressed as a percentage of cement weight.

A-8.3 Thickness

Cement mortar coating shall be uniform in thickness except in joints or other discontinuities in the pipe. Coatings shall be 20 mm minimum thickness for all sizes of pipe up to unless otherwise specified by the purchaser. Ends of coatings shall be uniform and square to the longitudinal axis of the pipe, and the coating holdback shall be as specified by the purchaser for the type of joint required.

A-9 REINFORCEMENT**A-9.1 General**

Unless otherwise specified by the purchaser, the reinforcement of the coating of pipe sections may be spiral wire, wire fabric, or wire mesh (ribbon mesh). Reinforcement shall be free of oil, grease, and other contaminants that might reduce the adherence between the coating and reinforcement. All reinforcement shall be placed in the middle third of the coating. When cement mortar coating is applied over a dielectric undercoat, the reinforcement shall not be attached to or otherwise be in contact with the steel pipe.

A-9.2 Spiral Wire

Attachment of ends and splices in the wire shall be by welding or other suitable means acceptable to the purchaser. Maximum spacing of the wire shall be 35 mm. The wires on 50 mm spacing on the 50 mm × 100 mm fabric shall extend circumferentially around the pipe.

A-9.3 Wire Mesh

Attachment of ends and splices in the wire shall be as approved by the purchaser. When 25 mm × 25 mm, 8 mm the spiral lap shall be 35 mm and the spliced lap 110 mm minimum.

A-10 APPLICATION OF MORTAR COATING**A-10.1 Application**

Mortar coating shall be applied by mechanical or

IS 3589 : 2001

pneumatic placement to the specified thickness in one or more continuous application(s). Allowance shall be made for splices of reinforcing wire. If applied in more than one course, the interval between the first and last course shall be not more than 2 h. The mortar shall be projected at high velocity against the exterior surfaces of the pipe or shall be applied by an equivalent method to produce a hard, tight adhering coating of the specified thickness.

A-10.2 Defective Coating

A-10.2.1 Sand Pockets and Porous Spots

If any sand pockets or porous spots occur, they shall be completely cut out and replaced by pneumatic placement or hand application of mortar in the proportion of 2 parts sand to 1 part cement, by weight.

A-10.2.2 Coating Cracks

Care shall be exercised to minimize the occurrence of cracks in the mortar coating. However, hairline cracks need not be repaired. Repair procedures shall include the brushing or wiping of neat cement into the cracks, autogenous healing of the cracks by additional moist curing, the painting of the cracks with an epoxy coating, or a combination of these methods.

NOTE — Repair procedure involving extensive chipping or routing of the cracks should be avoided as this procedure tends to deepen and lengthen the existing cracks and may damage the bond or adhesion between the coating and the cylinder.

A-10.3 Curing of Coating

A-10.3.1 General

After the initial set has taken place, the mortar coating shall be cured by the moist or accelerated curing methods or unless otherwise specified by the purchaser, a membrane material may be applied immediately following the coating application. Moist and

accelerated curing may be used interchangeably on a time ratio basis of 5 h or moist curing to 1 h of accelerated curing, except curing temperatures shall not exceed the maximum allowable for dielectric undercoat material.

The coating shall be kept continually moist by intermittent or continuous spraying for a period of at least four days. Moist curing may be used only if the minimum ambient temperature exceeds 5°C continuously during the minimum required curing period, and no credit shall be allowed for any time during which the temperature drops below 10°C.

A-10.4 Accelerated Curing

Accelerated curing of the pipe or special may begin immediately after completion of the coating operation or within 6 h thereafter. The temperature of the pipe or special shall not exceed 30°C until the cement mortar coating has taken its initial set or until a period of 3 h has elapsed, whichever occurs first. The relative humidity shall be not less than 85 percent at a temperature between 45 to 65°C for at least 18 h.

A-10.5 Membrane Curing

Membrane curing shall consist of the complete encapsulation of the coating by application of a material that will retain the moisture of the applied cement mortar coating.

A-10.6 Manufacture

During the entire period of the application of the lining and coating and the curing thereof, the section shall be carefully supported and handled to avoid damage to the mortar. If a pipe section must be moved, such operation shall be done with every reasonable precaution to protect against damage. Any damaged portion of the lining or coating shall be cut out and replaced.

ANNEX B

(Foreword and Clause 16.1)

LIQUID-EPOXY COATING SYSTEMS FOR THE INTERIOR AND EXTERIOR OF STEEL PIPELINES

B-1 COATING AND LINING SYSTEMS

Unless specified otherwise by the purchaser, the coating and lining systems may consist of any of the following three types: (1) two-part, chemically cured epoxy primer and one or more coatings of a different two-part, chemically cured epoxy topcoat; (2) two or more coats of the same two-part, chemically cured epoxy coating, in which case the first coat shall be considered as the prime coat; or (3) a single coat of a two-part, solvent free, chemically cured epoxy coating.

B-1.1 Liquid-Epoxy Coatings

The coatings used shall be based on liquid, chemically cured epoxies. The curing agent may be an amine, amine-adduct, or polyamide; and the epoxy may be modified with the coal rat, phenolic, or other modifiers. Materials used in both the primer and finish coat(s) shall be products of one manufacturer.

B-1.2 Coating Thickness

Unless otherwise specified by the purchaser, the minimum dry film thickness DFT provided shall be at least 406 μm .

After curing but prior to burial, the coating system shall be a continuous film, free of thin spots and other imperfections as defined and shall pass electrical inspection.

B-1.3 Coating Application

B-1.3.1 General

The pipe coating shall be applied in accordance with the manufacturer's recommendations. Application by airless spray or centrifugal wheel equipment is preferred.

B-2 PIPE PREPARATION

B-2.1 Cleaning

Prior to abrasive blast cleaning, surfaces shall be inspected and, if required, cleaned according to remove oil, grease, or other foreign matter. Only approved solvents that do not leave a residue shall be used. Preheating to remove oil, grease, mill scale, water and ice may be used provided all pipe is preheated in a uniform manner to avoid distorting the pipe.

B-2.2 Abrasive Blast Cleaning

The exterior pipe surfaces shall be abrasive blast cleaned

to achieve a near white metal surface. The interior pipe surfaces shall be abrasive blast cleaned to achieve a white metal surface. Abrasive blasting and coating shall only be performed when the metal temperature is more than 3°C above dew point.

B-2.3 Surface Inspection

The exterior and interior pipe surfaces shall be inspected for surface imperfections, such as slivers, scabs, burrs, weld spatter, and gouges, shall be removed by grinding.

B-2.4 Interior Cleaning

If abrasives or other loose foreign matter has entered the interior of the pipe, then clean, dry oil free compressed air shall be used to remove the loose foreign matter in a manner that does not adversely affect the cleaned surface. Alternatively, vacuum cleaning or other methods may be used in place of compressed air.

B-2.5 Pipe Ends for Non-welded Field Joints

When rubber gasketed joints or mechanical couplings are used, the coating shall extend to the ends of the pipe. The coating thickness on the pipe surfaces that receive rubber sealing gaskets shall not exceed what is recommended by the manufacturer of the coupling. However, the coating system's dry film thickness shall not be less than 406 μm .

B-2.6 Application Temperature

The temperature of the mixed coating material and of the pipe at the time of application shall not be lower than 10°C. Preheating of the coating material, the use of in line heaters to heat the coating material; or heating of the pipe, fittings or specials may be used to facilitate the application. Heating shall conform to the recommendations of the coating manufacturer.

B-2.7 Application of Epoxy Coating System

If more than one coat is applied, the second coat shall be applied within the time limits, surface conditions, and temperature recommended by the manufacturer, if the period between coats is exceeded, then a repair procedure shall be obtained from the coating manufacturer and its recommendations followed.

B-3 CURE

After application, the coating system shall be tested for cure.

B-4 ELECTRICAL INSPECTION FOR CONTINUITY

After curing, but prior to installation, the coating system applied to the pipe shall be tested for holidays according to the procedures and using the voltage settings. Any holidays indicated by the detector shall be marked with chalk or felt-tip marker to identify the area to be repaired.

B-5 COATING REPAIR

Accessible areas of pipe requiring coating repairs shall be cleaned to remove debris and damaged coating using surface grinders or other means acceptable to the purchaser. The adjacent coating shall be feathered by sanding, grinding, or other methods approved by the purchaser. Accumulated debris shall be removed by vacuum, blowing, or wiping with clean rags.

Areas not accessible by coating repair, such as interior surfaces of small diameter pipe, shall be reprocessed and recoated. Repairs shall be electrically inspected using a holiday detector. The coated pipe shipped from the plant shall be holiday free.

B-6 WELDED FIELD JOINTS

B-6.1 Preparation

The weld joint shall be cleaned so as to be free from mud, oil, grease, welding flux, weld spatter, and other foreign contaminants. The cleaned metal surfaces of the weld joint shall then be abrasive blasted, vacuum blasted, or abraded using rotary abrading pads. The adjacent liquid epoxy coating shall be feathered by abrading the coating surface for a distance of 25 mm.

B-6.2 Electrical Inspection

After curing, the coating system applied to the welded joints shall be holiday tested. Any holidays indicated by the detector shall be marked with chalk or felt-tip marker to identify the area for repair.

B-6.3 Bedding and Trench Backfill

Where the trench traverses rocky ground containing hard objects that could penetrate the protective coating, a layer of screened earth, sand, or rounded river run gravel not less than 150 mm thick with a maximum particle size of 20 mm shall be placed in the bottom of the trench prior to installation of the coated article.

ANNEX C

(Foreword and Clause 16.1)

FUSION-BONDED EPOXY COATING FOR THE INTERIOR AND EXTERIOR OF STEEL PIPELINES

C-1 MATERIAL

The epoxy powder shall consist of a one-component, fusion bonded material consisting of epoxy resin, curing agents, catalysts, fillers, colourants, flow control agents, and ultraviolet light resistant agents that when applied to the preheated substrate, will uniformly coalesce and cure to produce a homogeneous film that complies with the requirements of this standard.

Application capability, when applied by electrostatic spray, fluidized bed, or air spray to the preheated article and subsequently cured, the epoxy powder shall produce a uniform protective coating.

C-2 PIPE COATING APPLICATION

C-2.1 General

When both an internal and an external coating are to be applied, it is preferable to preheat the pipe to the specified temperature and apply the internal coating first, immediately followed by the external coating, since elevated temperatures are required during

processing, fusion bonded epoxy coating must be applied prior to the application of other coatings or linings unless those coatings and linings are resistant to the processing heat.

C-2.2 Surface Condition

Surfaces to be coated shall be free from mud, mill lacquer, wax, coal tar, asphalt, oil, grease, chlorides, or any other deleterious material. Prior to blast cleaning, surfaces shall be inspected and, if required, precleaned, to remove oil, grease, and loosely adhering deposits. Heating to remove oil, grease, mill scale, water, and ice may be used provided the pipe section, is preheated in a uniform manner to avoid distortion.

C-2.3 Blast Cleaning

The pipe surfaces to be coated shall be blast cleaned to achieve a near white surface.

C-2.4 Surface Inspection

The cleaned exterior and interior pipe surfaces shall

be inspected for adequate surface preparation. Surface imperfections such as slivers, scabs, burrs, weld spatter, and gouges shall be removed by hand filing or grinding to prevent holidays in the applied coating.

C-2.5 Interior Cleaning

If abrasives or other loose foreign matter have entered the interior of the pipe, then clean, dry, oil-free compressed air shall be used to remove the loose foreign matter in a manner that does not affect the surface of the pipe that is to be coated. Vacuum cleaning or other methods may be used in place of compressed air cleaning.

C-2.6 Preheating

Preheat temperature should be in accordance with the coating manufacturer's recommendations but shall not exceed 250°C.

C-2.7 Pipe Ends

Coating shall be held back in from the ends of pipe sections to be joined by field welding. This requirement applies to both the interior and exterior surfaces of the pipe. When rubber gasketed joints or mechanical couplings are used, the coating shall extend to the ends of the pipe unless otherwise specified by the purchaser.

C-2.8 Thickness

The coating powder shall be applied to the preheated pipe at a uniform cured-film thickness of not less than 300 microns on the exterior and not less than 375 microns on the interior.

C-2.9 Cooling

After the coating has cured in accordance with the time/temperature requirements of the coating manufacturer, the coating may be cooled with air or water spray to a temperature below 90°C to facilitate

handling for inspection and repair.

C-2.10 Imperfections

On completion of the coating operation, the coating shall be visually inspected for blisters, bubbles, voids, or other discontinuities. The coatings shall also be electrically inspected for holidays. Inspection and repair may commence after the pipe has cooled to 90°C or below.

C-3 COATING REPAIR

C-3.1 Minor Defects

Coating requiring repair due to scars, slivers, coating imperfections and other small defects shall be repaired using repair materials from the same manufacturer as the fusion bonded epoxy or any other compatible material approved by the purchaser and the applicator.

C-3.2 Major Defects

Pipe sections with coating defects, such as particle coating, unbounded coating, or inadequate film thickness, shall be reprocessed starting with surface preparation procedures.

C-3.3 Field Welded Joints

The weld area shall be heated to a temperature not to exceed 260°C using a circumferential induction heating coil of sufficient size, width, and power to provide the required heat in the weld zone and 55 mm back under the fusion bonded pipe coating.

Immediately after heating, the weld shall be coated with a powder coating. The welded joint coating shall overlap the original pipe coating by no less than 25 mm.

The exterior of field welded joints may be coated with hot applied tape, cold applied tape, liquid epoxy, or heat shrinkable coatings.

ANNEX D

(Foreword and Clause 16.1)

TAPE COATING SYSTEM

D-1 GENERAL

For corrosion protection of metal pipes often several outer wraps, hot or cold applied are used. For very corrosive soil condition cold applied tapes are used on steel pipes at site. In the factory normally hot applied tape coating are used. Unless the transportation is made very carefully these factory applied tape coating may get damaged.

For normal construction considerations cold applied tapes are applied as a three layer system consisting:

- a) Primer,
- b) Corrosion preventive tape (inner layer), and
- c) Mechanical protective tape (outer layer).

D-2 OUTER LAYER TAPE

The outer layer shall consist of polyolefin backing with a laminated elastomer type adhesive. The outer layer tape shall be compatible with the inner layer tape. The function of the outer layer tape shall be primarily to provide mechanical and outdoor weathering protection to the tape system and secondarily, to contribute to the overall corrosion protection properties of the system.

D-3 PRIMER

The primer shall be applied to the properly prepared pipe surface before application of the inner layer tape. The fusion bonding medium between the pipe surface and inner layer tape.

D-4 INNER LAYER TAPE

The inner layer tape shall consist of a polyolefin backing with a laminated adhesive. The inner layer tape shall be applied after the primer and before the outer layer tape.

The primary purpose of the inner layer tape is to provide the corrosion protection coating.

D-5 TOTAL COATING SYSTEM

The total thickness of the system made up of inner tape and outer tape may vary depending on pipe diameter operating condition and installation conditions. In no case shall the thickness be less than those given below:

The tapes can be applied directly onto the primed pipe surface by means of mechanical coating/wrapping equipment manually or by machine. The inner layer tape shall be specially applied with overlap width and application tensions as recommended by the manufacturers. The minimum overlap shall be not less than 25 mm when a new roll of tape is started and the ends shall be overlapped at least 150 mm measured circumferentially. The overlap shall be smooth and shall be located to ensure the continuity of the inner layer coating. The outer layer tape shall be applied over the inner layer tape using the same technique.

The overlap of the outer layer shall not coincide with the overlap of the inner layer tape. The minimum overlap of the applied tape and minimum end tap of two rolls shall be same as specified for inner tape.

**AMENDMENT NO. 3 MARCH 2006
TO
IS 3589 : 2001 STEEL PIPES FOR WATER
AND SEWAGE (168.3 TO 2540 mm OUTSIDE
DIAMETER) — SPECIFICATION**

(Third Revision)

(Title & General) — Delete the word 'gas' wherever it appears in the standard.

Substitute '168.3 mm outside diameter and above' for '168.3 to 2 032 mm outside diameter' wherever it appears.

(Page 2, clause 7.3) — Insert the following new clause after 7.3:

'7.3.1 Whenever agreed between the manufacturer and the purchaser, a maximum of two circumferential welds are permissible to make a full length. The tests for such tubes shall be mutually agreed. Minimum length of jointed tubes shall not be less than 1.5 meter.'

(Page 6, Table 5) — The mass of pipes of following sizes for the specified thickness and OD may be modified as given below:

Sl No.	Outside Diameter	Thickness	Mass
	mm	mm	kg/m
1	168.3	3.2	13.0
2	273	6.3	41.4
3	323.9	4.0	31.6
4	610	5.8	86.4
5	813	18	352.9
6	1 067	10	260.7
7	1 829	14.2	635.5

Amend No. 3 to IS 3589 : 2001

(*Page 9, Annex A, clause A-2*) — Insert the following sentence at the end of para:

'Alternatively 4 mm wire with a pitch of 50 mm may be wrapped over lined steel cylinder pipe with the tension of 50 to 65 MPa.'

(*Page 13, Annex B, clause B-1.1, line 4*) — Substitute the words 'coal tar' for 'coal rat'.

(MTD 19)

A-3.2 Preparation of a Composite Sample — From the material from each selected container remaining after the individual sample has been taken, equal quantities of the material shall be taken and mixed together so as to form a composite sample weighing not less than 60 g. This composite sample shall be divided into three approximately equal parts and transferred to clean and dry glass containers and labelled with the particulars given in A-1.5. One of these composite samples shall be marked for the purchaser, the other for the vendor, and the third for the referee.

A-3.3 Referee Samples — Referee samples shall consist of a set of individual samples (*see* A-3.1) and a composite sample (*see* A-3.2) marked for this purpose and shall bear the seals of the purchaser and the vendor. These shall be kept at a place agreed between the two.

A-4. NUMBER OF TESTS

A-4.1 Tests for requirements in respect of protein and granularity shall be conducted on each of the samples constituting a set of individual test samples (*see* A-3.1).

A-4.2 Tests for the remaining characteristics, namely moisture, total ash, acid insoluble ash, crude fibre and alcoholic acidity, shall be conducted on the composite sample (*see* A-3.2).

A-5. CRITERIA FOR CONFORMITY

A-5.1 The lot shall be considered satisfactory in respect of the requirements of A-4.1, if each individual sample satisfies all the requirements.

A-5.2 The lot shall be considered satisfactory in respect of the requirements of A-4.2, if the test results on the composite sample satisfy the corresponding requirements.

A-5.3 The lot shall be declared to be in conformity with all the requirements of this specification, if it has been found satisfactory in accordance with A-5.1 and A-5.2.

(*Clause G-1.2*) — Substitute the following for the existing clause:

'G-1.2 Standard Sodium Hydroxide Solution — 0.05 N.'

(*Clause G-1.3*) — Substitute the following for the existing clause:

'G-1.3 Phenolphthalein Indicator Solution — Dissolve 0.1 g of phenolphthalein in 100 ml of 60 percent rectified spirit.'

(Clause G-2.1) — Substitute the following for the existing clause:

'G-2.1 Weigh 5 g of the sample into a conical glass stoppered flask and add 50 ml of 90 percent alcohol (by volume) previously neutralized against phenolphthalein. Stopper, shake and allow to stand for 24 hours, with occasional shaking. Filter the alcoholic extract through a dry filter paper. Titrate 10 ml of the combined alcoholic extract against the standard sodium hydroxide using phenolphthalein as indicator. Calculate the percentage of alcoholic acidity as sulphuric acid.'

(Clause G-3.1, line 3) — Substitute $\frac{24.52 AN}{W}$
for $\frac{12.25 AN}{W}$

Bureau of Indian Standards

BIS is a statutory institution established under the *Bureau of Indian Standards Act, 1986* to promote harmonious development of the activities of standardization, marking and quality certification of goods and attending to connected matters in the country.

Copyright

BIS has the copyright of all its publications. No part of these publications may be reproduced in any form without the prior permission in writing of BIS. This does not preclude the free use, in the course of implementing the standard, of necessary details, such as symbols and sizes, type or grade designations. Enquiries relating to copyright be addressed to the Director (Publications), BIS.

Review of Indian Standards

Amendments are issued to standards as the need arises on the basis of comments. Standards are also reviewed periodically; a standard along with amendments is reaffirmed when such review indicates that no changes are needed; if the review indicates that changes are needed, it is taken up for revision. Users of Indian Standards should ascertain that they are in possession of the latest amendments or edition by referring to the latest issue of 'BIS Catalogue' and 'Standards : Monthly Additions'.

This Indian Standard has been developed from Doc : No. MTD 19 (4194).

Amendments Issued Since Publication

Amend No.	Date of Issue	Text Affected

BUREAU OF INDIAN STANDARDS

Headquarters:

Manak Bhavan, 9 Bahadur Shah Zafar Marg, New Delhi 110 002
Telephones : 2323 0131, 2323 3375, 2323 9402 Website : www.bis.org.in

Regional Offices :

	Telephones
Central : Manak Bhavan, 9 Bahadur Shah Zafar Marg NEW DELHI 110 002	{ 2323 7617 2323 3841
Eastern : 1/14 C. I. T. Scheme VIIM, V. I. P. Road, Kankurgachi KOLKATA 700 054	{ 2337 8499, 2337 8561 2337 8626, 2337 9120
Northern : SCO 335-336, Sector 34-A, CHANDIGARH 160 022	{ 260 3843 260 9285
Southern : C. I. T. Campus, IV Cross Road, CHENNAI 600 113	{ 2254 1216, 2254 1442 2254 2519, 2254 2315
Western : Manakalaya, E9 MIDC, Marol, Andheri (East) MUMBAI 400 093	{ 2832 9295, 2832 7858 2832 7891, 2832 7892

Branches : AHMEDABAD. BANGALORE. BHOPAL. BHUBANESHWAR. COIMBATORE.
FARIDABAD. GHAZIABAD. GUWAHATI. HYDERABAD. JAIPUR. KANPUR.
LUCKNOW. NAGPUR. NALAGARH. PATNA. PUNE. RAJKOT. THIRUVANANTHAPURAM.
VISAKHAPATNAM.